

GasMultiBloc
Combined regulator and
safety shut-off valves
Single-stage function
Integrated bypass valve

DUNGS®

MB-D(LE) 405 - 412 B07

7.08

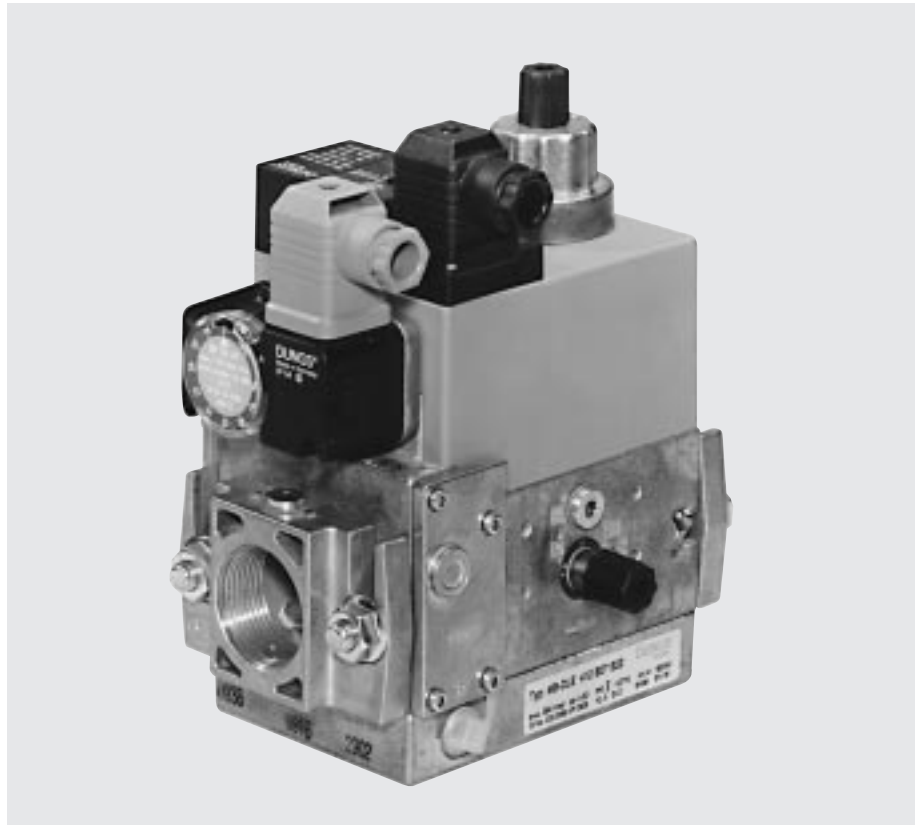

Technical description

The DUNGS GasMultiBloc integrates filter, regulator, valves and pressure switches in one compact fitting. Various designs are possible by the modular system:

- Dirt trap unit: microfilter
- One regulator, two main valves and one bypass valve: B07
- Two valves are fast opening, one valve is slow opening
- Solenoid valves up to 360 mbar as per DIN EN 161 Class A Group 2
- Sensitive setting of output pressure by proportional regulator as per DIN EN 88 Class A Group 2
- High flow rates with low pressure drop
- DC solenoid drive interference degree N
- Main volume restrictor at valve V2, bypass restrictor at valve V3
- Hydraulic opening delay
- Flange connections with pipe threads as per ISO 7/1
- Simple mounting, compact, lightweight

The modular system permits individual solutions by using an internal bypass valve in connection with separately controlled valves, by adding a valve proving system, mini/maxi pressure switches, pressure limiters, limit switches at valve V2.

Application

The modular system permits individual solutions in gas safety and regulator engineering. Suitable for gases of families 1, 2, 3 and other neutral gaseous media.

Approvals

EU type test approval as per EU Gas Appliance Directive.

MB-...405...B07	CE-0085 AP 0802
MB-...407...B07	CE-0085 AP 0803
MB-...410...B07	CE-0085 AP 0804
MB-...412...B07	CE-0085 AP 0805

Approvals in other important gas-consuming countries.

Functional description of gas flow

1. When the valves V1 and V2 are closed, chamber A is under inlet pressure.
2. A hole D in the filter housing connects min. pressure switch with chamber A. If the inlet pressure applied to the pressure switch exceeds the incoming reference value, it switches through to the automatic burner control.
3. After release by the automatic burner control, valves V1 and V3 open. The gas flows through chambers A, B and via bypass valve V3 in C of the GasMultiBloc. The ignition gas volume is adjusted by using the bypass restrictor. The pressure regulator controls the pressure upstream of valves V2 and V3.
4. When valve V2 is released, the gas flows directly into chamber C, the bypass valve V3 remains open.

Operating method of valve-regulator combination on valve V1

A regulator, compensating for residual pressure is integrated in valve V1 (pressure regulating part).

Armature 7 is not connected to the valve plate unit 3. When it opens, armature 7 pretensions compression spring (V1) 5 and releases the valve plate unit.

When the valve closes, the armature acts directly on the valve plate unit.

The output pressure upstream of valve V2 is defined by pretensioning the regulating spring 8 (tension spring) via setting screw 17. The output pressure acts via opening E on the working diaphragm 26 of the regulator. In regulated state, setting spring inlet pressure and pressure of working diaphragm are in force equilibrium. The compensating diaphragm ensures the fast closing function of valve V1 and a high regulating quality.

Operating method of bypass valve V3

The bypass valve V3 opens at the same time as valve V1. Ignition gas flow is set by using bypass restrictor 21.

Operating method of valve V2

Armature 14 of valve V2 is connected to valve plate unit 12. When it opens, armature 14 pretensions compression spring 13. The maximum valve opening can be set by limiting the armature stroke by means of the main volume restrictor 18.

Min. opening (residual stroke) of valve (0.5 to 1.0 mm)

The main volume restrictor is set by rotating the adjusting plate or the hydraulic brake. The fast and/or slow opening characteristic is influenced by setting fast stroke 19 at the hydraulic brake under the cover.

Closing function

When the supply voltage to the main valve solenoid coils is interrupted, valves V1, V3 and V2 are closed within < 1 s by the compression springs.

Sectional drawing of MB-DLE...B07

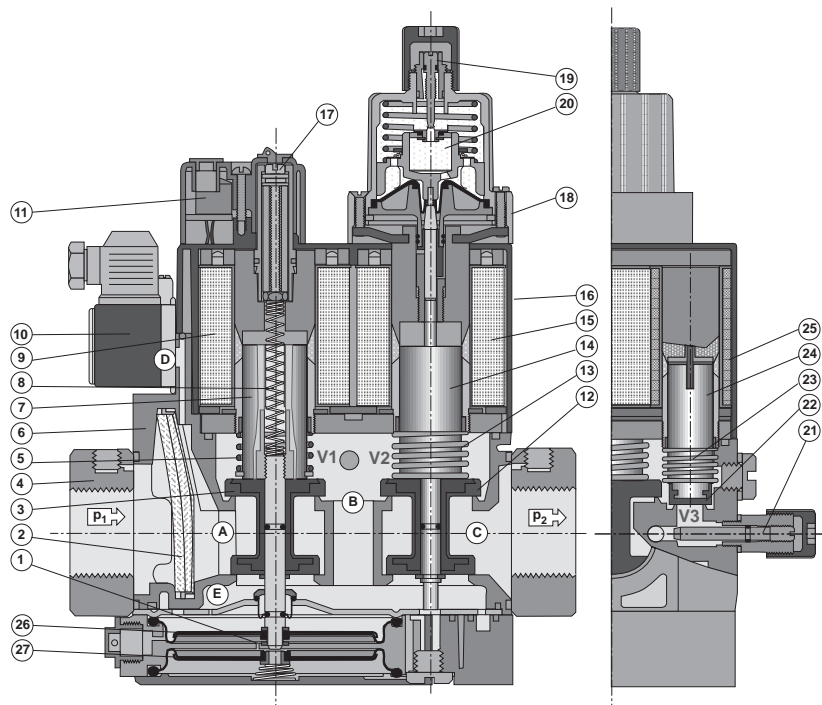

1	Pressure regulator	11	Electrical connection	21	Bypass restrictor
2	Microfilter	12	Valve V2	22	Valve V3
3	Valve V1	13	Closing spring V2	23	Closing spring V3
4	Connection flange	14	Armature V2	24	Armature V3
5	Closing spring V1	15	Solenoid V2	25	Solenoid V3
6	Housing	16	Solenoid housing	26	Working diaphragm
7	Armature V1	Setting:		27	Compensation diaphragm
8	Regulating spring	17	- Gas pressure p_a		
9	Solenoid V1	18	- Main volume		
10	Gas pressure switch (optional)	19	- Fast stroke		
		20	Hydraulic brake		

Pressure taps

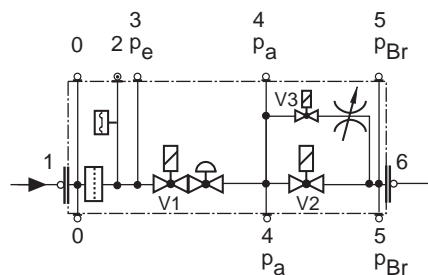

- 0 Filter cover
- 1, 3, 4, 6 G 1/8 screw plug
- 2 Test nipple
- 5 M4 screwed sealing plug

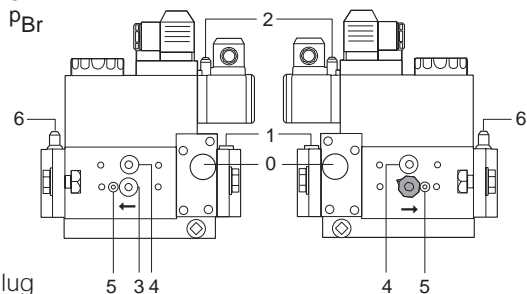

Electrical connection

IEC 730-1 (VDE 0631 T1)

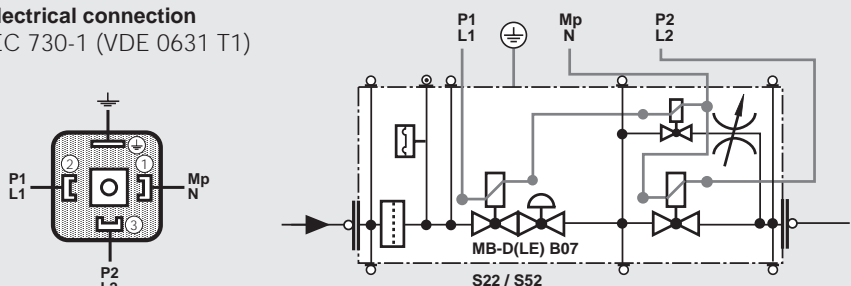

Specifications

Nominal diameters Flange with pipe threads as per ISO 7/1 (DIN 2999)	MB-...405/407 B07 Rp 1/2, 3/4 and their combinations	MB-...410/412 B07 Rp 3/4, 1, 1 1/4 and their combinations																				
Max. operating pressure	360 mbar (36 kPa)																					
Output pressure ranges	MB-... S22 p_a: 4 mbar to 20 mbar MB-... S52 p_a: 4 mbar to 50 mbar																					
Pressure stage	PN 1																					
Media	Gases of families 1, 2, 3 and other neutral gaseous media																					
Ambient temperature	-15 °C to +70 °C (Do not operate MB-D below 0 °C in liquid gas systems. Only suitable for gaseous liquid gas, liquid hydrocarbons destroy sealing materials.)																					
Dirt trap	Sieve with 0.8 mm mesh width, filter made of random laid nonwoven fabric, microfilter, two-layer, changing the filter is possible without removing the valve.																					
Pressure switches	Types GW A5, GW A2, NB A2, ÜB A2 mountable as per DIN EN 1854. For further information, refer to Datasheet GW A2 No. 215 183 and Datasheet GW A5 No. 225 901.																					
Pressure regulator	Pressure regulator compensated for residual pressure, leakproof seal when switched off by means of valve V1 as per DIN EN 88 Class A. Setpoint spring permanently installed (no spring exchange possible). A vent line above roof is not required. Internal pulse tap provided.																					
Solenoid valve V1	Valve as per DIN EN 161 Class A Group 2, fast closing, fast opening																					
Solenoid valve V2	Valve as per DIN EN 161 Class A Group 2																					
	<table border="1"> <thead> <tr> <th></th> <th colspan="2">Valve V2 design</th> <th>Main volume restrictor</th> </tr> </thead> <tbody> <tr> <td>MB</td> <td>fast closing</td> <td>fast opening</td> <td>without</td> </tr> <tr> <td>MB-D</td> <td>fast closing</td> <td>fast opening</td> <td>with</td> </tr> <tr> <td>MB-DLE</td> <td>fast closing</td> <td>slow opening</td> <td>with</td> </tr> <tr> <td>MB-LE</td> <td>fast closing</td> <td>slow opening</td> <td>without</td> </tr> </tbody> </table>			Valve V2 design		Main volume restrictor	MB	fast closing	fast opening	without	MB-D	fast closing	fast opening	with	MB-DLE	fast closing	slow opening	with	MB-LE	fast closing	slow opening	without
	Valve V2 design		Main volume restrictor																			
MB	fast closing	fast opening	without																			
MB-D	fast closing	fast opening	with																			
MB-DLE	fast closing	slow opening	with																			
MB-LE	fast closing	slow opening	without																			
Solenoid valve V3 (bypass)	Valve as per DIN EN 161 Class A Group 2, with volume restrictor																					
Measuring/ignition gas connection	For G 1/8 as per DIN ISO 228, refer to Pressure taps on page 2																					
Burner pressure monitor p _{Br}	Connection downstream of valve V2, pressure switch mountable on adapter laterally																					
Voltage / frequency	50-60 Hz ,220 - 230 V AC, -15% +10% Other preferred voltages: 240 VAC, 110-120 VAC, 48 VDC, 24-28 VDC																					
Electrical connection	Plug connection as per DIN 43 650, IEC 335, IEC 730 (VDE 0700, VDE 0722) for valves and pressure switches																					
Rating/power consumption Switch-on duration Degree of protection Radio interference	Refer to Dimensions on page 5 100% IP 54 as per IEC 529 (EN 60529) Interference degree N																					
Materials of gas conveying parts	Housing Diaphragms, seals Solenoid drive	aluminium die casting NBR basis, Silopren (silicone rubber) steel, brass, aluminium																				
Installation position	Solenoid vertically upright or lying horizontally as well as its intermediate positions.																					
Closed position signal contact	Closed position signal contact, type K01/1 (DIN-tested), mountable on V2																					

Equipment variants GasMultiBloc...B07 Single-stage function	405 B07	407 B07	410 B07	412 B07	
MB	•	•	•	•	
MB-D	•	•	•	•	
MB-DLE	•	•	•	•	
MB-LE	•	•	•	•	
Microfilter (standard) with sieve	•	•	•	•	
Gas pressure switch downstream of filter	•	•	•	•	
downstream of valve V2 on adapter	•	•	•	•	
Pressure regulator	•	•	•	•	
Valve V1, double seat	•	•	•	•	
Valve V2, single seat	•	–	•	–	
Valve V2, double seat	–	•	–	•	
Valve V3, single seat with restrictor	•	•	•	•	
Valve opening separately	•	•	•	•	S...2 version
Flange Rp 1/2	•	•	–	–	<ul style="list-style-type: none"> • = possible (•) = on request - = not possible
Rp 3/4	•	•	•	•	
Rp 1	–	–	•	•	
Rp 1 1/4	–	–	•	•	

MB...B07 version

- V1 = Valve 1**
- V2 = Valve 2**
- V3 = Valve 3**
- 4 = Filter**
- 5 = Pressure switch, optional**
- 6 = Regulator**

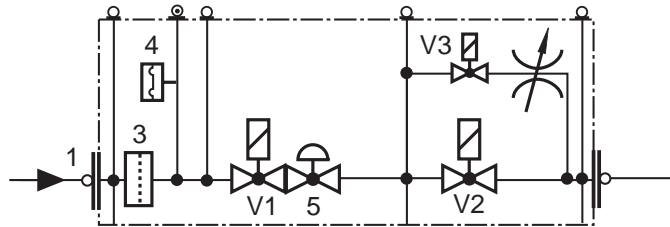

Mounting of VPS 504 valve proving system possible
 Mounting of K01/1 closed position signal contact possible

Type key of MultiBloc

MB- XX XXX XX BOX SXX

Control of V1 and V2

0 = common
2 = separated

Outlet pressure Inlet pressure
 2 = 4 - 20 mbar up to 360 mbar
 5 = 4 - 50 mbar up to 360 mbar

S = Series (type-independent)

Gas train schematic diagram
 1 = two A valves for main gas + regulator
 2 = two A valves for main gas
 7 = two A valves for main gas, one A valve together with V1 as internal bypass around V2 + regulator

Design type (generation) B

Construction size, nominal diameter
 403 = DN 10, V2 = Single-seat valve
 405 = DN 15, V2 = Single-seat valve
 407 = DN 20, V2 = Double-seat valve
 410 = DN 25, V2 = Single-seat valve
 412 = DN 32, V2 = Double-seat valve
 415 = DN 40, V2 = Double-seat valve
 420 = DN 50, V2 = Double-seat valve

Opening behaviour + main volume restrictor

without = (MB or MB-ZR)
 -D = Main volume restrictor
 -LE = adjustable opening behaviour
 -DLE = D + LE combination

without = single stage
 ZR = double-stage with partial volume setting first stage

MultiBloc

Dimensions [mm]

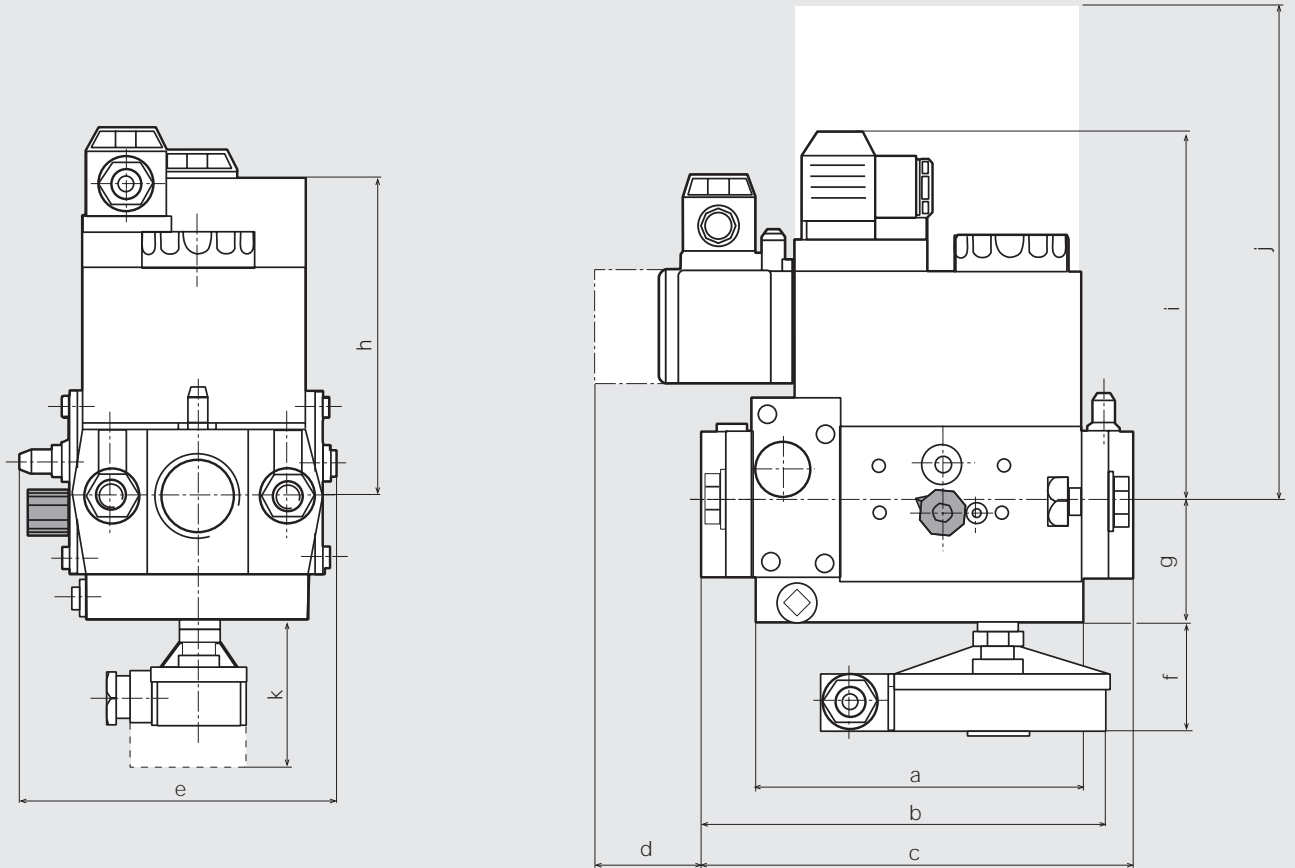

- d = Space requirement for cover of pressure switch
- j = Space requirement for exchanging the solenoid
- k = Space requirement for K01/1 closed position signal contact

Type	Nominal rating [VA]		Dimensions [mm]										Weight [kg]	
	230 V AC; +20 °C	S22 S52	a	b	c	d	e	f	g	h	i	j		k
MB-D 405/407 B07	46	46	110	151	155	40	120	50	46	115	100	185	80	2.5
MB-DLE 405/407 B07	46	46	110	151	155	40	120	50	46	115	140	185	80	2.6
MB-D 410/412 B07	110	110	140	185	185	40	145	50	55	135	125	245	80	4.8
MB-DLE 410/412 B07	110	110	140	185	185	40	145	50	55	135	160	245	80	4.9

Volumetric flow pressure loss characteristic via bypass valve V3, restrictor open

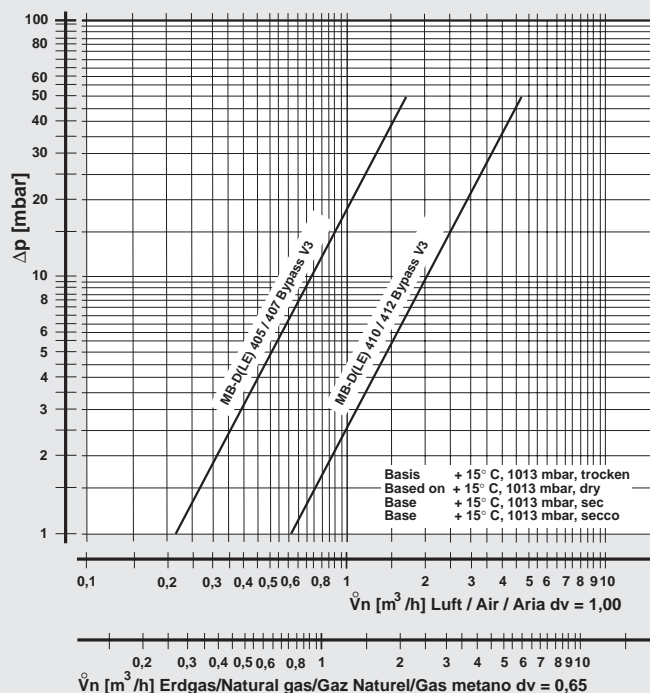

GasMultiBloc
Combined regulator and
safety shut-off valves
Single-stage function
Integrated bypass valve

MB-D(LE) 405 - 412 B07

DUNGS®

Volumetric flow pressure loss characteristics in regulated state with microfilter

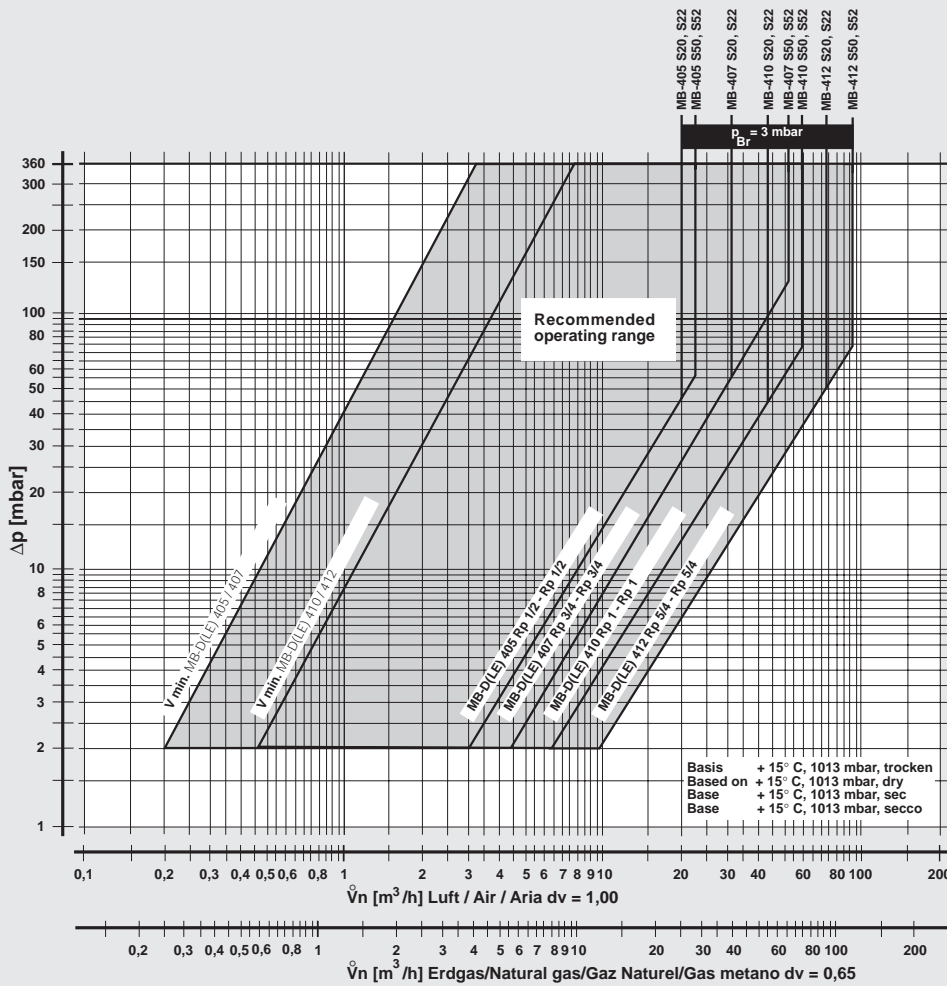

Basis + 15° C, 1013 mbar, trocken
 Based on + 15° C, 1013 mbar, dry
 Base + 15° C, 1013 mbar, sec
 Base + 15° C, 1013 mbar, secco

$$f = \sqrt{\frac{\text{Dichte Luft}}{\text{Dichte des verwendeten Gases}}}$$

Spec. weight air / poids spécifique de l'air / peso specifico aria

Spec. weight of gas used / poids spécifique du gaz utilisé / peso specifico del gas utilizzato

Gas type	Density [kg/m³]	dv	f
Nat. gas	0.81	0.65	1.24
City gas	0.58	0.47	1.46
LPG	2.08	1.67	0.77
Air	1.24	1.00	1.00

$$\dot{V}_{\text{verwendetes Gas/gas used/ gaz utilisé/gas utilizzato}} = \dot{V}_{\text{Luft/air/air/aria}} \times f$$

We reserve the right to make any changes in the interest of technical progress.



Head Offices and Factory
Karl Dungs GmbH & Co.
Siemensstraße 6-10
D-73660 Urbach, Germany
Telephone +49 (0)7181-804-0
Fax +49 (0)7181-804-166

Postal address
Karl Dungs GmbH & Co.
Postfach 12 29
D-73602 Schorndorf, Germany
e-mail info@dungs.com
Internet www.dungs.com